

# ACRO

## Acro Aluminum (2024) Ltd

### 400T ACRO THERMALLY BROKEN DOOR Medium STILE

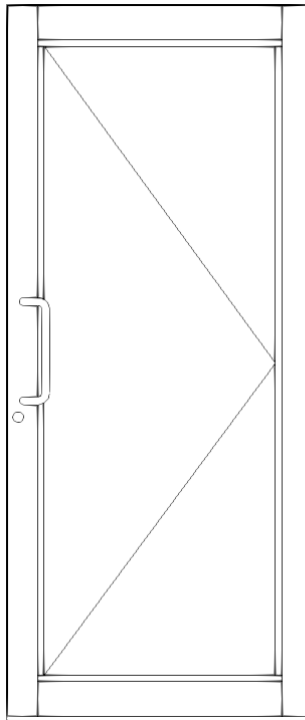

#### Overview

The Acro 400-T Series Thermal Aluminum Door combines durability with advanced thermal performance, making it ideal for modern commercial applications.

#### Key Features

- 3-1/2" (89 mm) Medium Stiles
- High performance glass reinforced nylon thermal break.
- Mechanically fastened
- Optional Foam Insulation to Lower Standard U-Value When Required.
- NFRC Rated.
- Accommodates 1" double or 1- 1 2" triple glazing units.

## **Specifications**

- Medium stile has 3 ½" (88.9mm) vertical stile, 4" (102mm) top and 4" (102mm) bottom
- Option for 4" (101.6mm) or 7 ½" (190.5mm) or 10" (254mm) bottom
- Door depth 2 ¼" (57mm)

## **MATERIALS**

- All aluminum to be 6063-T6 tempered.
- Thermal Break polyamide 6.6, 25% glass fiber reinforced.
- Gaskets to be silicone or EPDM.
- Stainless steel fasteners.

## **Performance**

- Designed for superior thermal efficiency, air tightness, and water resistance. Suitable for demanding building envelope conditions.

## **Available finishes**

- Clear Anodized.
- Dark Bronze Anodized (black).
- Custom color powder or Duracron. Compliant to AAMA 2604
- Option for different finish on interior and exterior

## **Hardware configuration**

- Continuous gear hinge
- Compatible with North American door locking and panic hardware
- Standard 9" commercial d-pull. Other pull styles available

## **COMPATIBILITY**

- Compatible with most store front and curtain wall systems
- Compatible with most commercial door hardware

## **Product Applications**

- Swing door entrances requiring durability of aluminum, high thermal performance, and high air/water penetration performance.

**DOOR SWINGS**

**Single Door Panels**

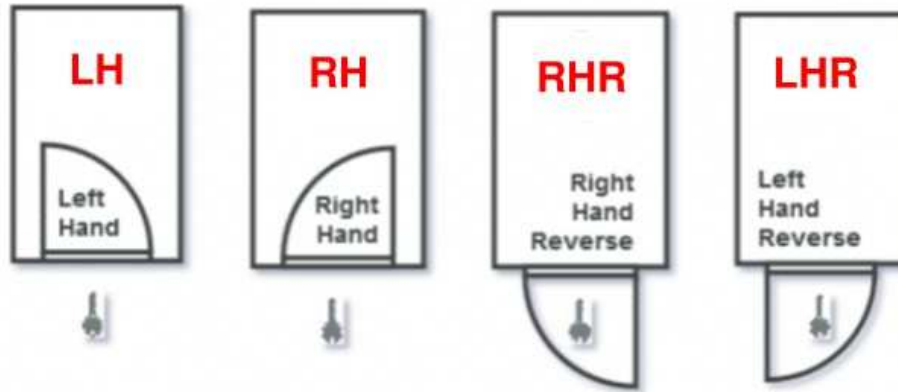

**Double Door Panels**

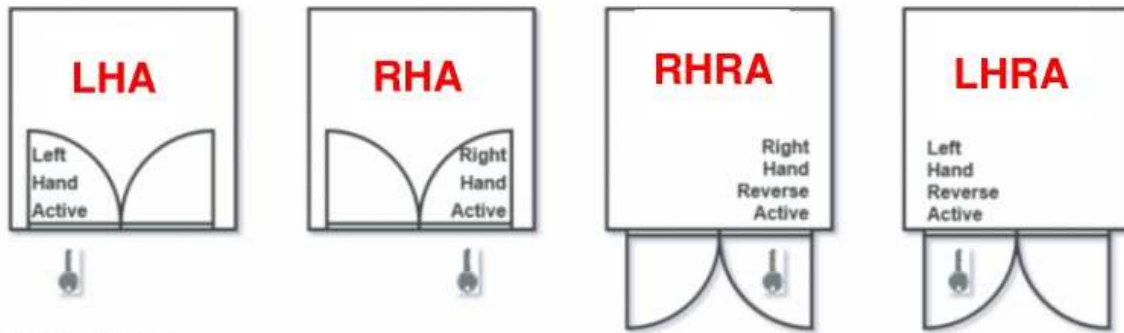

 = Key side of opening

## Summary of Test Results



Client: Acro Aluminum (2024) Ltd.  
 Project No.: QA-5048-DW-A-Revision 1  
 Date: April 28, 2026  
 Page 4 of 27

**PRODUCT RATINGS:**

Table 1: Summary of Test Results

Test Name	AAMA/WDMA/CSA 101/I.S.2/A440-22 NAFS and CSA A440S1-25 Results:
<b>Operating Force Test (Clause 8.3.1)</b>	Max. allowable force to open/close latching devices: 100 N (~22.5 lbf) Force to open/close latching device: Avg. force to open latching device = 37.2 N (~8.4 lbf) Avg. force to close latching device = 43.3 N (~9.7 lbf) Overall result - Pass requirements for CW classification.
<b>Air Leakage Resistance Test (ASTM E283)</b>	Pressure differential = 75 Pa Infiltration result = 0.353 L/s/m <sup>2</sup> (0.069 cfm/ft <sup>2</sup> ) Exfiltration result = 0.871 L/s/m <sup>2</sup> (0.171 cfm/ft <sup>2</sup> ) Max. allowable air leakage at ±75 Pa for CW Class = 1.000 L/s/m <sup>2</sup> (0.200 cfm/ft <sup>2</sup> ) Overall result – Pass requirements for CW classification.
<b>Water Penetration Resistance Test (ASTM E547)</b>	Maximum pressure differential = 0 Pa (DP LW – ~0.00 psf)
<b>Uniform Load Deflection Test at Design Pressure (ASTM E330 – Procedure A)</b>	Design pressure = 2400 Pa (DP 50 – ~50.13 psf) Maximum pressure differential = 2520 Pa (~52.63 psf) Maximum deflection at test pressure = 4.67 mm (~0.184") Max. L/175 deflection limit for LC Class = 12.62 mm (~0.497") The deflection measurement was taken along the locking side stile.
<b>Uniform Load Structural Test at 150% Design Pressure (ASTM E330 – Procedure A)</b>	Design pressure = 1680 Pa (DP 35 – ~35.09 psf) Maximum pressure differential = 2520 Pa (~52.63 psf) Maximum deformation after test pressure = 0.15 mm (~0.006") Maximum L*0.3% deformation limit for CW Class = 6.63 mm (~0.261")
<b>Forced Entry Resistance Test (AAMA 1304)</b>	Pass
<b>Vertical Loading Resistance Test (Clause 6.2.6.3)</b>	Load applied = 1112 N (~250.0 lbf) Overall result - Pass
<b>Operation / Cycle Performance (Clauses 6.2.6.2)</b>	Number of cycles required for CW class - 250,000 cycles Overall result - Pass

Table 2. Product Classification to NAFS 2022 and to CSA A440S1-25

<b>400T Series Out-Swing Side Hinged Door</b>	
<b>Maximum Size Tested:</b>	1085 mm wide x 2222 mm tall (~43 x 83 in)
<b>Performance Classification:</b>	CW
<b>Performance Grade:</b>	PG35
<b>Product Type:</b>	LW - SHD
<b>Primary Designator:</b> Class CW - PG35: Size tested 1085 x 2222 mm (~43 x 83 in) – Type LW - SHD	
<b>Secondary Designator:</b> Positive ASD Design Pressure (DP) = 1680 Pa (~35.09 psf) Negative ASD Design Pressure (DP) = -1680 Pa (~-35.09 psf) Water Penetration Resistance Test Pressure = 0 Pa (~0.00 psf) Air Infiltration / Exfiltration = Pass	

This report is the confidential property of the client addressed. The report may only be reproduced in full. Publication of extracts from this report is not permitted without written approval from QAI. Any liability attached thereto is limited to the fee charged for the individual project file referenced. The results of this report pertain only to the specific sample(s) evaluated. Unless specifically stated or identified otherwise, QAI has utilized a Simple Acceptance rule per ILAC-G8 Section 4.2.1 to make conformity decisions on testing results contained in this report, as applicable.

WWW.QAI.ORG  
 info@qai.org



Client: Acro Aluminum (2024) Ltd.  
 Project No.: QA-6407-DW-A  
 Date: April 28, 2026  
 Page 3 of 21

**TEST RESULTS SUMMARY:**  
**400T Series Out-Swing Side-Hinged Door**  
**Size: 960 mm x 2090 mm**

Class / Grille Bar Option #	Model Code	Number of Layers	Exterior Layer (mm)	Middle Layer (mm)	Interior Layer (mm)	Emissivity Surface 1	Emissivity Surface 2	Emissivity Surface 3	Emissivity Surface 4	Emissivity Surface 5	Emissivity Surface 6	Cavity 1 and 2 (mm)	Spacer Bar Type	Grille Bar	Foam Insulation or Reinforcement	Visual Transmittance Total Product	Product U-Factor (W/m <sup>2</sup> K)	Product SHGC
G01	AA-SSOSH-D-6,180(2)-6,CL-15AR90EN-F1	2	6 Cardinal LoE 180	-	6 Clear	-	0.068	-	-	-	-	14.5 90% Argon	EN	-	F1	0.44	2.54	0.37
G02	AA-SSOSH-D-6,270(2)-6,CL-15AR90EN-F1	2	6 Cardinal LoE 270	-	6 Clear	-	0.035	-	-	-	-	14.5 90% Argon	EN	-	F1	0.39	2.50	0.23
G03	AA-SSOSH-D-6,366(2)-6,CL-15AR90EN-F1	2	6 Cardinal LoE 366	-	6 Clear	-	0.020	-	-	-	-	14.5 90% Argon	EN	-	F1	0.36	2.48	0.18
G04	AA-SSOSH-D-6,180(2)-6,189(4)-15AR90EN-F1	2	6 Cardinal LoE 180	-	6 Cardinal LoE 189	-	0.035	-	0.149	-	-	14.5 90% Argon	EN	-	F1	0.44	2.28	0.36
G05	AA-SSOSH-D-6,270(2)-6,189(4)-15AR90EN-F1	2	6 Cardinal LoE 270	-	6 Cardinal LoE 189	-	0.068	-	0.149	-	-	14.5 90% Argon	EN	-	F1	0.38	2.39	0.22
G06	AA-SSOSH-D-6,366(2)-6,189(4)-15AR90EN-F1	2	6 Cardinal LoE 366	-	6 Cardinal LoE 189	-	0.020	-	0.149	-	-	14.5 90% Argon	EN	-	F1	0.36	2.30	0.17
G07	AA-SSOSH-D-6,180(2)-6,CL-15AR90EN	2	6 Cardinal LoE 180	-	6 Clear	-	0.068	-	-	-	-	14.5 90% Argon	EN	-	-	0.44	2.85	0.37
G08	AA-SSOSH-D-6,270(2)-6,CL-15AR90EN	2	6 Cardinal LoE 270	-	6 Clear	-	0.035	-	-	-	-	14.5 90% Argon	EN	-	-	0.39	2.82	0.23
G09	AA-SSOSH-D-6,366(2)-6,CL-15AR90EN	2	6 Cardinal LoE 366	-	6 Clear	-	0.020	-	-	-	-	14.5 90% Argon	EN	-	-	0.36	2.80	0.18
G10	AA-SSOSH-D-6,180(2)-6,189(4)-15AR90EN	2	6 Cardinal LoE 180	-	6 Cardinal LoE 189	-	0.035	-	0.149	-	-	14.5 90% Argon	EN	-	-	0.44	2.66	0.36

This report is the confidential property of the client addressed. The report may only be reproduced in full. Publication of extracts from this report is not permitted without written approval from QAI. Any liability attached thereto is limited to the fee charged for the individual project file reference. The results of this report pertain only to the specific sample(s) evaluated. Unless specifically stated or identified otherwise, QAI has utilized a Single Acceptance rule per ILAC-08 Section 4.2.1 to make conformity decisions on testing results contained in this report, as applicable.

WWW.QAI.ORG  
 info@qai.org



Client: Acro Aluminum (2024) Ltd.  
 Project No.: QA-6407-DW-A  
 Date: April 28, 2026  
 Page 4 of 21

Class / Grille Bar Option #	Model Code	Number of Layers	Exterior Layer (mm)	Middle Layer (mm)	Interior Layer (mm)	Emissivity Surface 1	Emissivity Surface 2	Emissivity Surface 3	Emissivity Surface 4	Emissivity Surface 5	Emissivity Surface 6	Cavity 1 and 2 (mm)	Spacer Bar Type	Grille Bar	Reinforcement or Foam Insulation	Visual Transmittance Total Product	Product U-Factor (W/m <sup>2</sup> K)	Product SHGC
G11	AA-SSOSH-D-6,270(2)-6,189(4)-15AR90EN	2	6 Cardinal LoE 270	-	6 Cardinal LoE 189	-	0.068	-	0.149	-	-	14.5 90% Argon	EN	-	-	0.36	2.63	0.22
G12	AA-SSOSH-D-6,366(2)-6,189(4)-15AR90EN	2	6 Cardinal LoE 366	-	6 Cardinal LoE 189	-	0.020	-	0.149	-	-	14.5 90% Argon	EN	-	-	0.36	2.62	0.17
G13	AA-SSOSH-D-6,270(2)-6,CL-6,180(6)-10AR90EN-F1	3	6 Cardinal LoE 270	6 Clear	6 Cardinal LoE 180	-	0.068	-	-	-	0.035	14.5 90% Argon	EN	-	F1	0.34	2.12	0.20
G14	AA-SSOSH-D-6,366(2)-6,CL-6,180(6)-10AR90EN-F1	3	6 Cardinal LoE 366	6 Clear	6 Cardinal LoE 180	-	0.020	-	-	-	0.035	14.5 90% Argon	EN	-	F1	0.31	2.12	0.16
G15	AA-SSOSH-D-6,270(2)-6,CL-6,189(6)-10AR90EN-F1	3	6 Cardinal LoE 270	6 Clear	6 Cardinal LoE 189	-	0.068	-	-	-	0.149	14.5 90% Argon	EN	-	F1	0.34	2.15	0.21
G16	AA-SSOSH-D-6,366(2)-6,CL-6,189(6)-10AR90EN-F1	3	6 Cardinal LoE 366	6 Clear	6 Cardinal LoE 189	-	0.020	-	-	-	0.149	14.5 90% Argon	EN	-	F1	0.32	2.14	0.16
G17	AA-SSOSH-D-6,270(2)-6,180(4)-6,189(6)-10AR90EN-F1	3	6 Cardinal LoE 270	6 Cardinal LoE 180	6 Cardinal LoE 189	-	0.068	-	0.020	-	0.149	14.5 90% Argon	EN	-	F1	0.33	2.03	0.20
G18	AA-SSOSH-D-6,270(2)-6,CL-6,180(6)-10AR90EN	3	6 Cardinal LoE 270	6 Clear	6 Cardinal LoE 180	-	0.068	-	-	-	0.035	14.5 90% Argon	EN	-	-	0.34	2.43	0.20
G19	AA-SSOSH-D-6,366(2)-6,CL-6,180(6)-10AR90EN	3	6 Cardinal LoE 366	6 Clear	6 Cardinal LoE 180	-	0.020	-	-	-	0.035	14.5 90% Argon	EN	-	-	0.31	2.43	0.16
G20	AA-SSOSH-D-6,270(2)-6,CL-6,189(6)-10AR90EN	3	6 Cardinal LoE 270	6 Clear	6 Cardinal LoE 189	-	0.068	-	-	-	0.149	14.5 90% Argon	EN	-	-	0.34	2.45	0.21
G21	AA-SSOSH-D-6,366(2)-6,CL-6,189(6)-10AR90EN	3	6 Cardinal LoE 366	6 Clear	6 Cardinal LoE 189	-	0.020	-	-	-	0.149	14.5 90% Argon	EN	-	-	0.32	2.45	0.16
G22	AA-SSOSH-D-6,270(2)-6,180(4)-6,189(6)-10AR90EN	3	6 Cardinal LoE 270	6 Cardinal LoE 180	6 Cardinal LoE 189	-	0.068	-	0.020	-	0.149	14.5 90% Argon	EN	-	-	0.33	2.34	0.20

This report is the confidential property of the client addressed. The report may only be reproduced in full. Publication of extracts from this report is not permitted without written approval from QAI. Any liability attached thereto is limited to the fee charged for the individual project file referenced. The results of this report pertain only to the specific sample(s) evaluated. Unless specifically noted or identified otherwise, QAI has utilized a single Acceptance rate per UL-C-98 Section 4.2.1 to make conformity decisions on testing results contained in this report, as applicable.

WWW.QAI.ORG  
 Info@qai.org

## ENERGY PERFORMANCE – U-VALUE BY GLASS TYPE

 THERMAL PERFORMANCE TABLE (ALL OPTIONS)

## ◆ DOUBLE GLAZING – WITH FOAM (BEST PERFORMANCE PRODUCT)

Option	Glass Configuration	U (W/m <sup>2</sup> ·K)	U (Btu/ft <sup>2</sup> ·hr·°F)	SHGC
G01	LoE180 / Argon / Clear	2.54	0.447	0.37
G02	LoE270 / Argon / Clear	2.50	0.440	0.23
G03	LoE366 / Argon / Clear	2.48	0.437	0.18
G04	LoE180 / Argon / i89	2.28	0.401	0.36
G05	LoE270 / Argon / i89	2.39	0.421	0.22
G06	LoE366 / Argon / i89	2.30	0.405	0.17

## ◆ DOUBLE GLAZING – NO FOAM (STANDARD PRODUCT)

Option	Glass Configuration	U (W/m <sup>2</sup> ·K)	U (Btu/ft <sup>2</sup> ·hr·°F)	SHGC
G07	LoE180 / Argon / Clear	2.85	0.502	0.37
G08	LoE270 / Argon / Clear	2.82	0.497	0.23
G09	LoE366 / Argon / Clear	2.80	0.493	0.18
G10	LoE180 / Argon / i89	2.66	0.468	0.36
G11	LoE270 / Argon / i89	2.63	0.463	0.22
G12	LoE366 / Argon / i89	2.62	0.461	0.17

## ◆ TRIPLE GLAZING – (WITH FOAM) (BEST PERFORMANCE PRODUCT)

Option	Glass Configuration	U (W/m <sup>2</sup> ·K)	U (Btu/ft <sup>2</sup> ·hr·°F)	SHGC
G13	LoE270 / Clear / LoE180	2.12	0.373	0.20
G14	LoE366 / Clear / LoE180	2.12	0.373	0.16
G15	LoE270 / Clear / i89	2.15	0.379	0.21
G16	LoE366 / Clear / i89	2.14	0.377	0.16
G17	LoE270 / LoE180 / i89	<b>2.03</b>	<b>0.357</b>	0.20

## ◆ TRIPLE GLAZING – WITHOUT FOAM (STANDARD PRODUCT)

Option	Glass Configuration	U (W/m <sup>2</sup> ·K)	U (Btu/ft <sup>2</sup> ·hr·°F)	SHGC
G18	LoE270 / Clear / LoE180	2.43	0.428	0.20
G19	LoE366 / Clear / LoE180	2.43	0.428	0.16
G20	LoE270 / Clear / i89	2.45	0.432	0.21
G21	LoE366 / Clear / i89	2.45	0.432	0.16
G22	LoE270 / LoE180 / i89	2.34	0.412	0.20

## ACRO THERMALLY BROKEN DOOR 400T Medium STILE

### Double Glazed

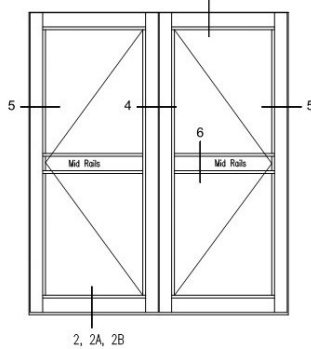

Pair Door

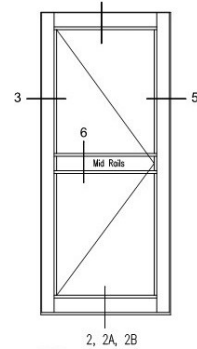

Single Door

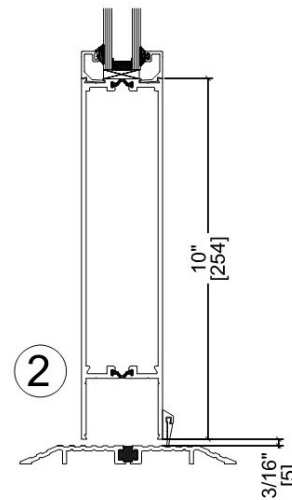
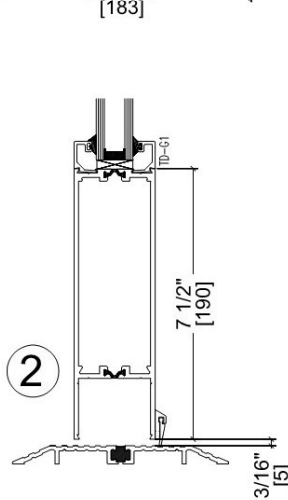
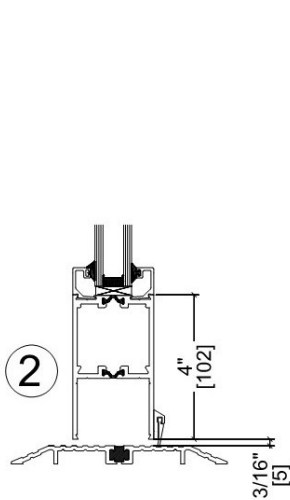
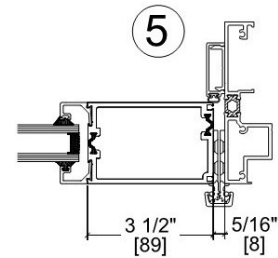
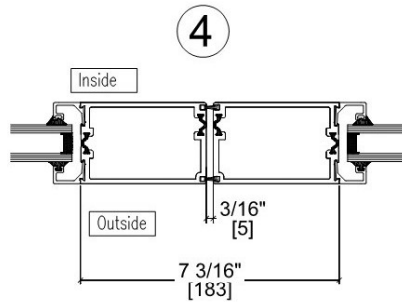
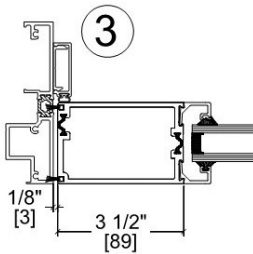
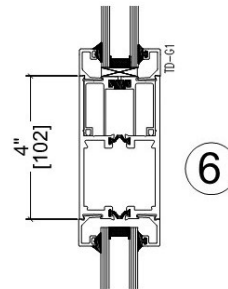
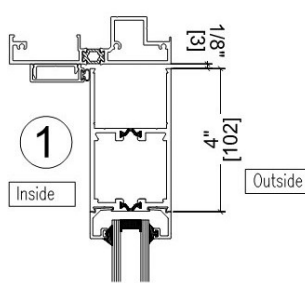

## ACRO THERMALLY BROKEN DOOR 400T Medium STILE

### Double Glazed with Foam option

NOTE: High Performance Series 400T Shown With Optional Foam Insulation to Lower Standard U-Value When Required.

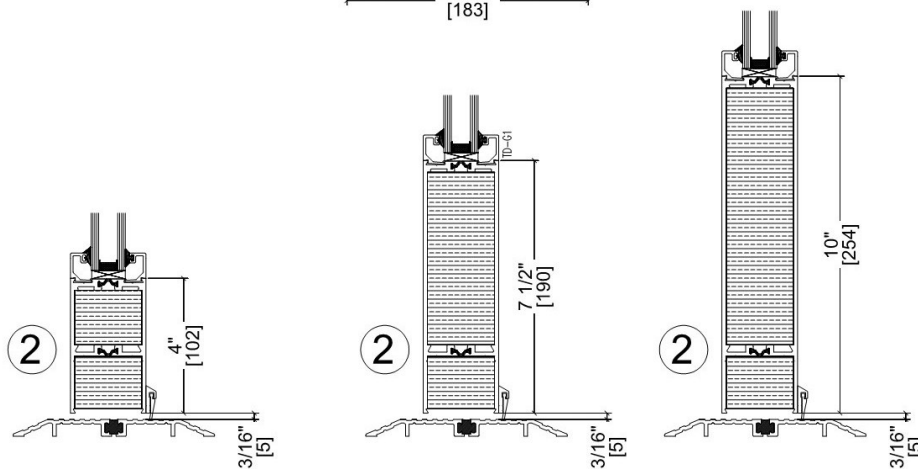
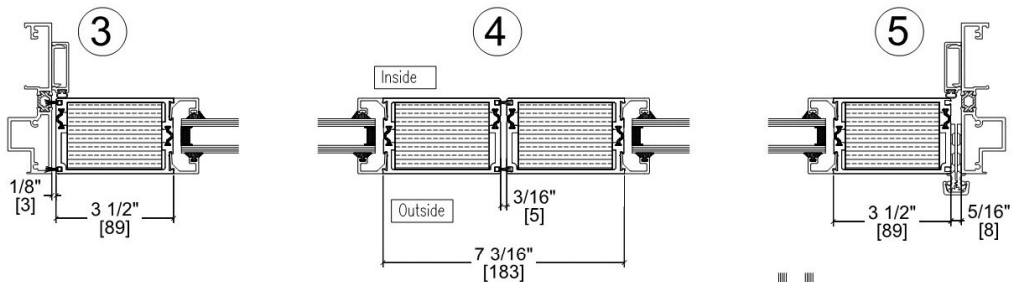
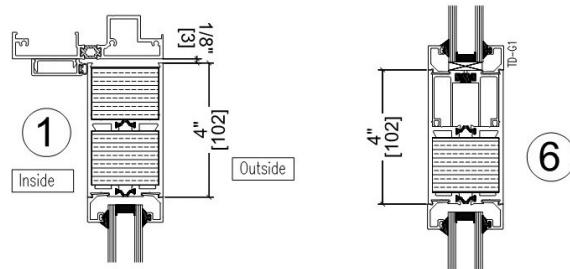
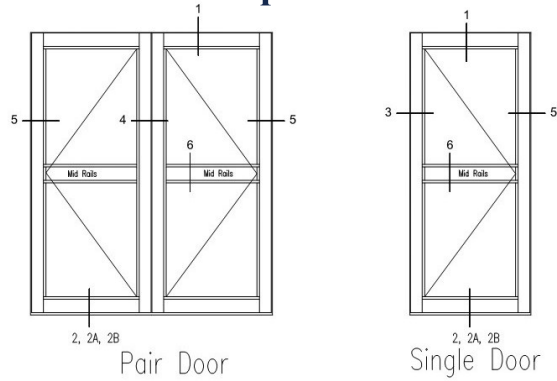

# ACRO THERMALLY BROKEN DOOR 400T Medium STILE

## Triple Glazed

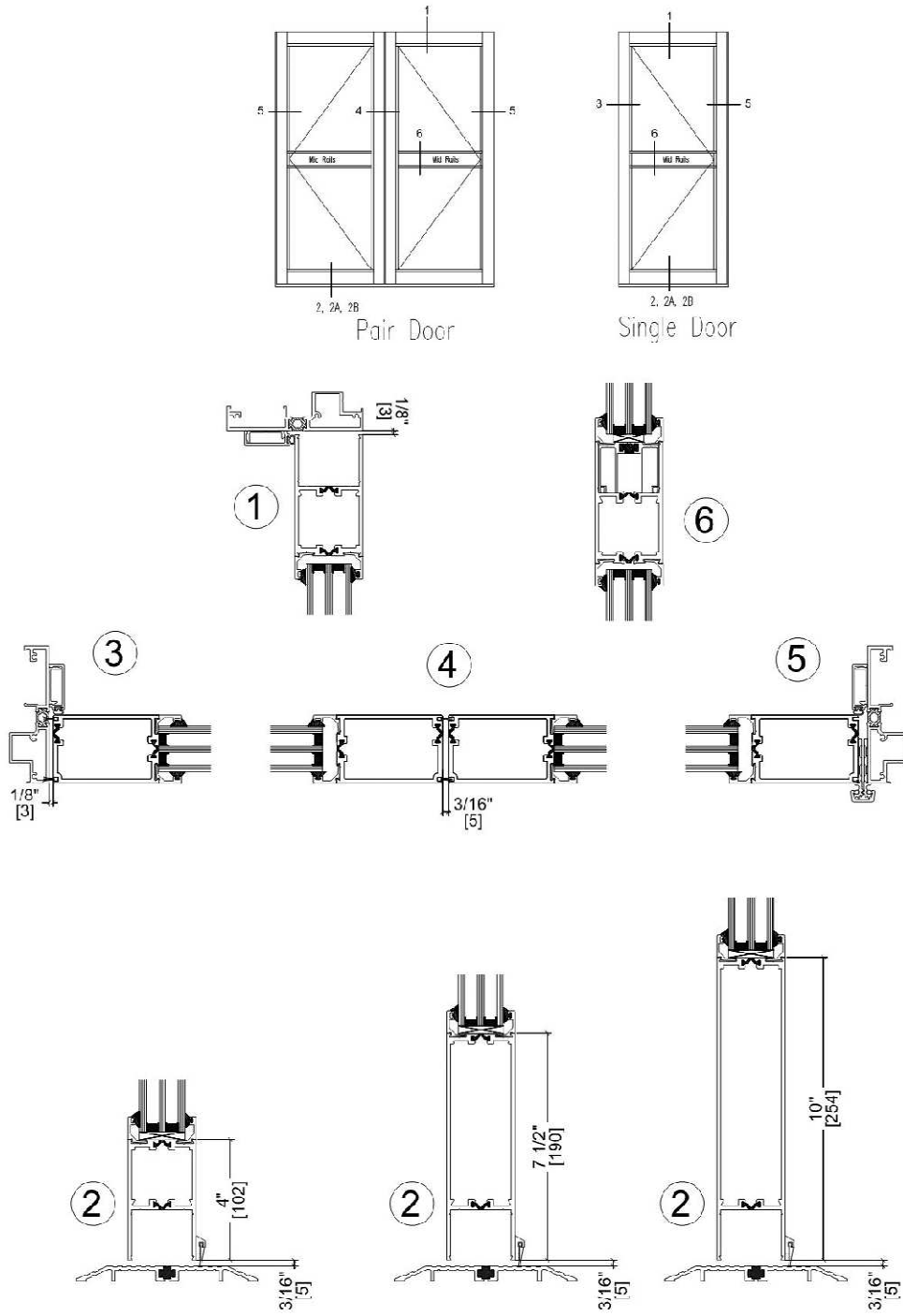

## ACRO THERMALLY BROKEN DOOR 400T Medium STILE

### Triple Glazed with Foam option

NOTE: High Performance Series 400T Shown With Optional Foam Insulation to Lower Standard U-Value When Required.

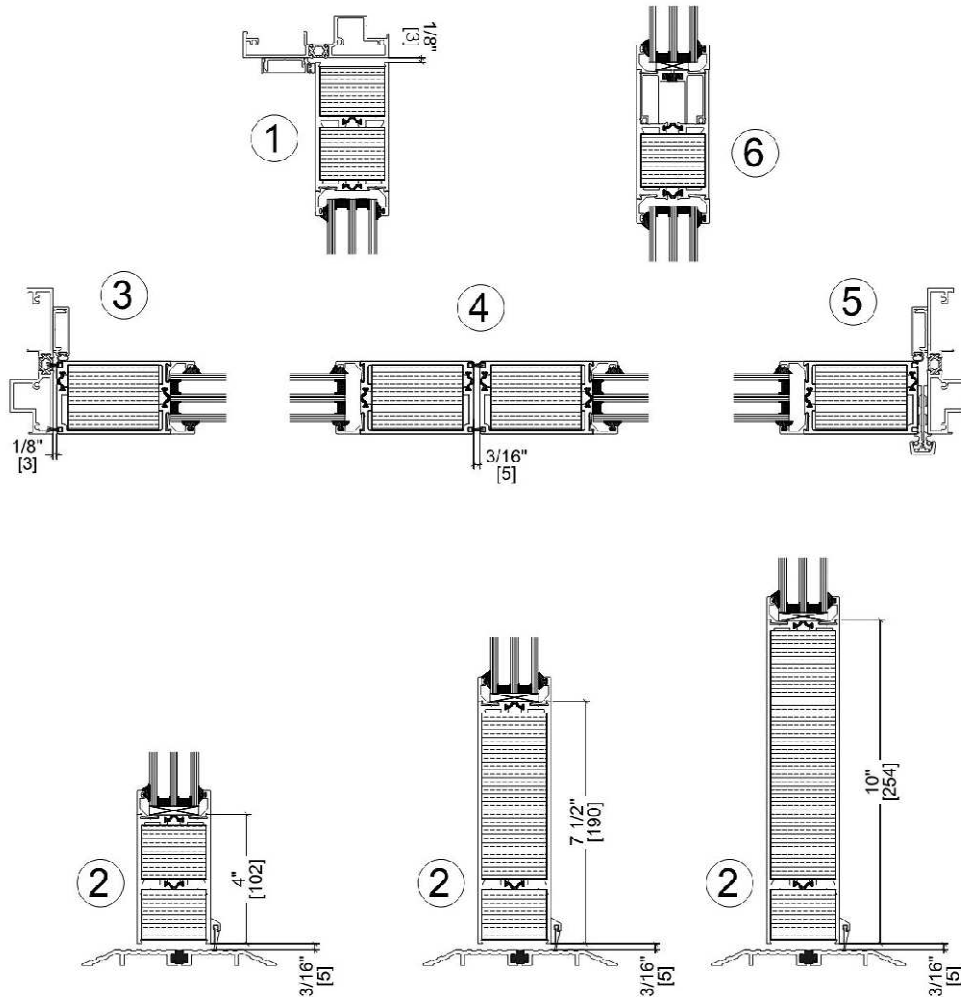
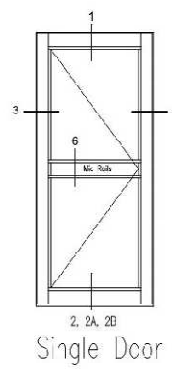
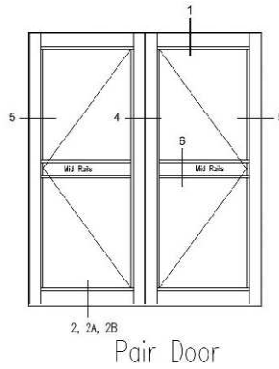

### CONSTRUCTION DETAILS - CURTAIN WALL

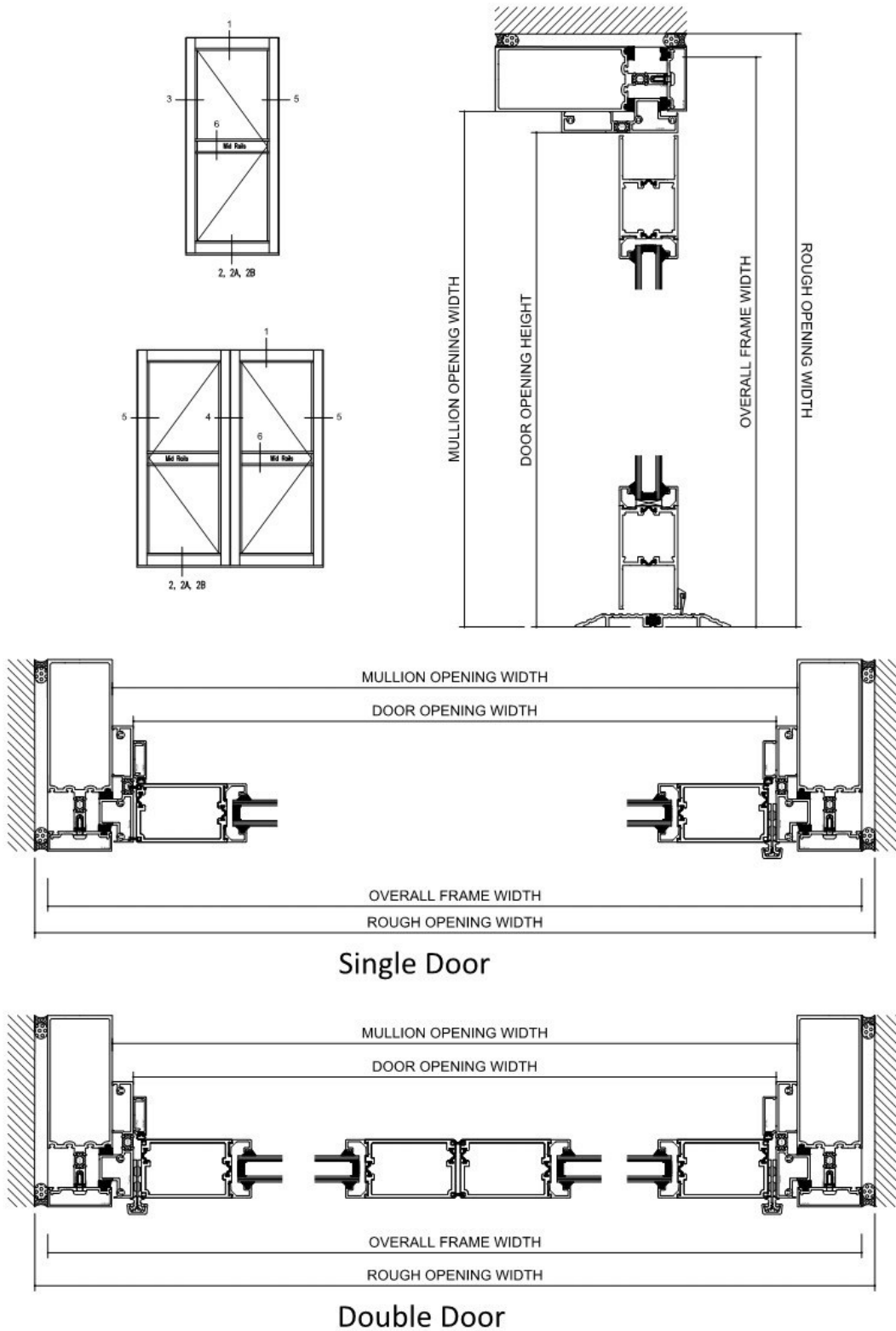



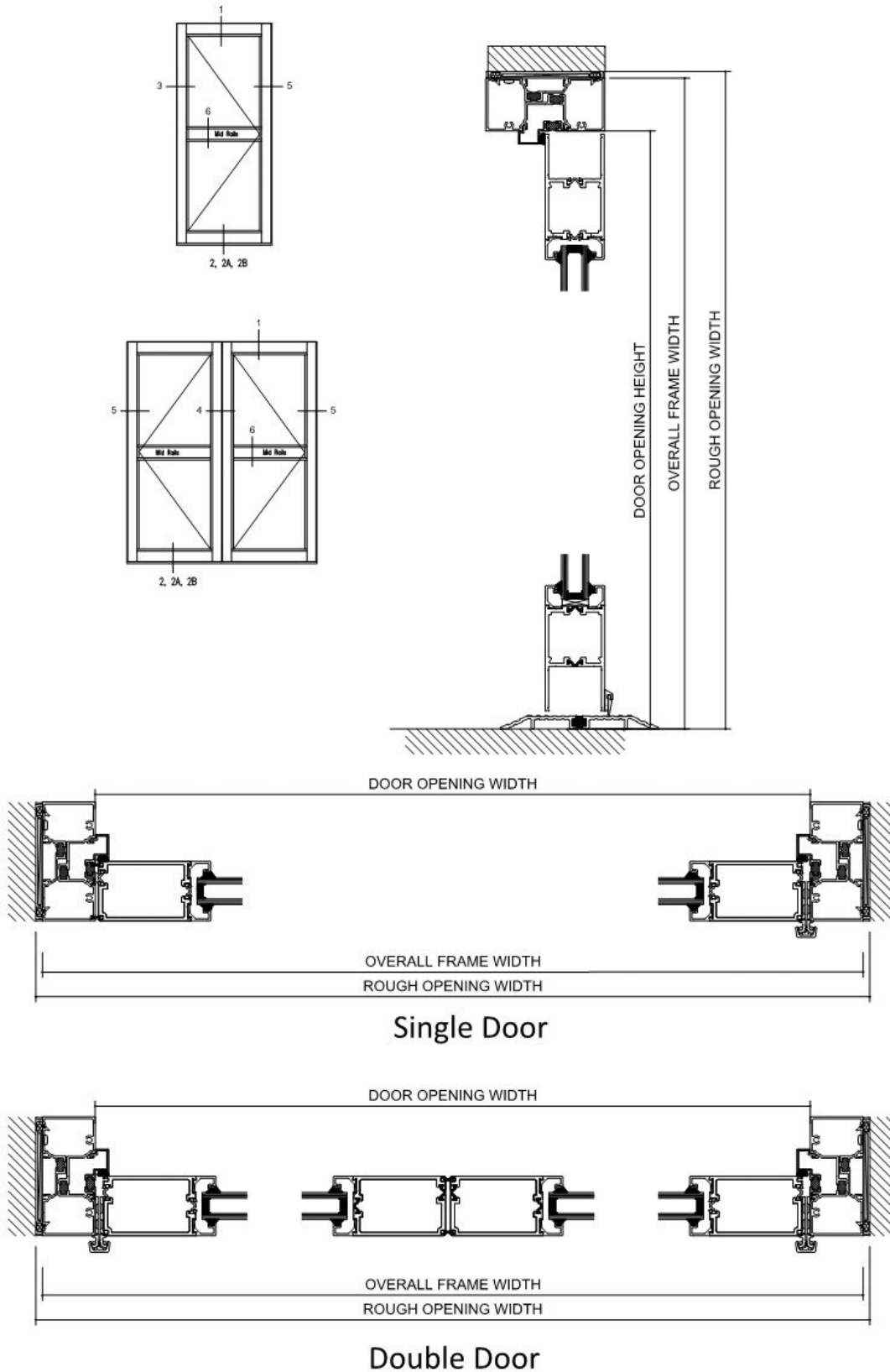





### CONSTRUCTION DETAILS - STOREFRONT





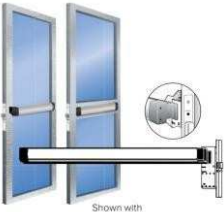

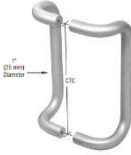
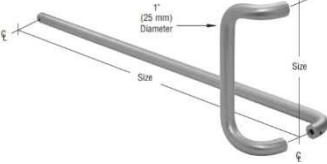

Single Door

Double Door

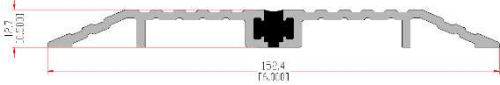
## Standard Door Hardware

Description	Picture
Security Latch Lock	
Security deadbolt/hook bolt Lock	
Security Key Cylinder	
Security Mortise Thumb turn Cylinder	
8400 Series or similar Narrow Stile Mortise Exit Device CVR and Rim Panic are also available.	 <p style="text-align: center; font-size: small;">Shown with 8475 mid-panel</p>
Security push paddle. Clear or Black.	
Acro Aluminum 9" offset Pull Handle Back- to-back in clear and black Ano. 9" from screw to screw.	
Acro Aluminum Push Bar	
Surface closer. Clear or Black	

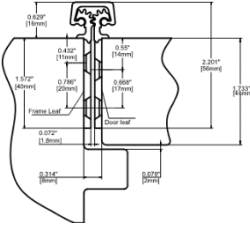
<p>Security lever handle.</p>	
<p>Electric strike AR 7100</p>	
<p>Threshold 6 x 1/2" thermally broken</p>	
<p>Door sweep 3/8" brush Clear and black</p>	
<p>Security Flush Bolt</p>	
<p>Astragal (Dog Tail) Clear and Black</p>	
<p>Full concealed gear hinge Clear and Black</p>	
<p>Armored loop cord</p>	